

Fitted to Last



FEATURES & BENEFITS

- Tested in accordance to BBA
- Available in Top Hung and Side Hung variants for 13 and 17mm stack height applications
- Manufactured from SUS 430 ferretic stainless steel
- Fire egress option available
- Suitable for all major profiles
- Quick and easy to fabricate
- Smooth glide operation



Fittings for Windows 17

HANDED STAY

The Vita handed friction stay range has been designed to ensure enhanced weather performance, smooth operation and durability for the life of the window.

The Vita "Sureclose" Nylon friction end cap guarantees a positive engagement of the sash and the frame part, optimising gasket compression.

KATANA

Fitted to Last

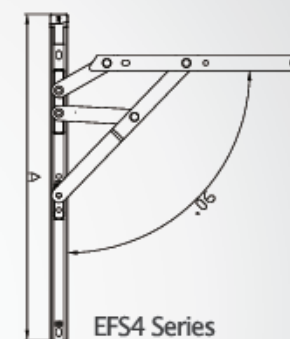
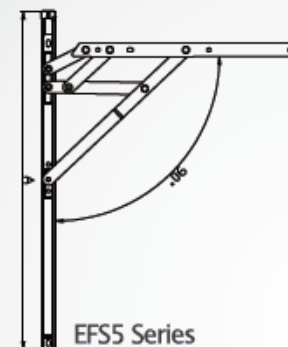
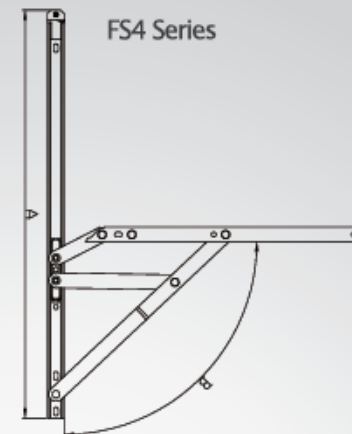
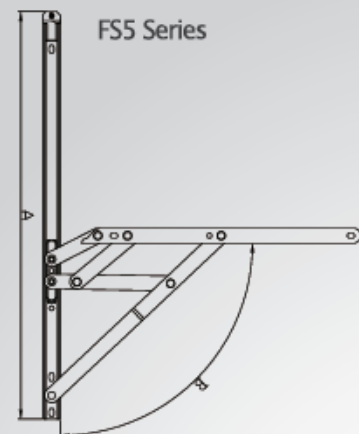

Fittings for Windows 18

Material:

- Links & Track, Rivet – Stainless Steel
- Slider – Nylon
- Screws – Brass



Sureclose Nylon friction end cap



BBA Assessment Report Number: S2/49995

RECOMMENDED MAXIMUM WINDOW WEIGHTS AND SIZES

Product Code	Size A	Application	Approx. Sash Width	Approx. Sash Height	Approx. Sash Weight	Stack height	Opening Angle B
FS408	8"	Top hung	1200mm	350mm	12kg	13mm & 17mm	60
FS410	10"	Top hung	1200mm	400mm	14kg	13mm & 17mm	60
FS412	12"	Top hung	1200mm	550mm	16kg	13mm & 17mm	90
FS416	16"	Top hung	1200mm	800mm	20kg	13mm & 17mm	65
FS520	20"	Top hung	1200mm	900mm	24kg	13mm & 17mm	50
FS524	24"	Top hung	1200mm	1300mm	50kg	13mm & 17mm	44
FS512	12"	Side hung	600mm	1200mm	22kg	13mm & 17mm	55
FS516	16"	Side hung	700mm	1350mm	24kg	13mm & 17mm	65
EFS412	12"	Side hung	600mm	1200mm	22kg	13mm & 17mm	90
EFS516	16"	Side hung	700mm	1350mm	24kg	13mm & 17mm	90